

optimisation

- [SQA] 1. A goldsmith has built up a solid which consists of a triangular prism of fixed volume with a regular tetrahedron at each end. The surface area, A , of the solid is given by

$$A(x) = \frac{3\sqrt{3}}{2} \left(x^2 + \frac{16}{x} \right)$$

where x is the length of each edge of the tetrahedron.

Find the value of x which the goldsmith should use to minimise the amount of gold plating required to cover the solid.

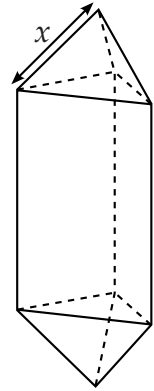

6

- [SQA] 2. A company spends x thousand pounds a year on advertising and this results in a profit of P thousand pounds. A mathematical model, illustrated in the diagram, suggests that P and x are related by $P = 12x^3 - x^4$ for $0 \leq x \leq 12$.

Find the value of x which gives the maximum profit.

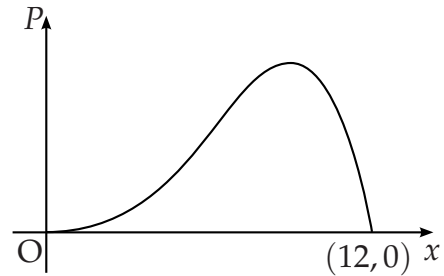

5

- [SQA] 3. The shaded rectangle on this map represents the planned extension to the village hall. It is hoped to provide the largest possible area for the extension.

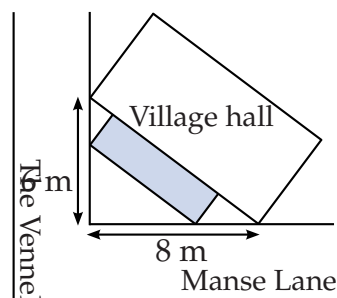

The coordinate diagram represents the right angled triangle of ground behind the hall. The extension has length l metres and breadth b metres, as shown. One corner of the extension is at the point $(a, 0)$.

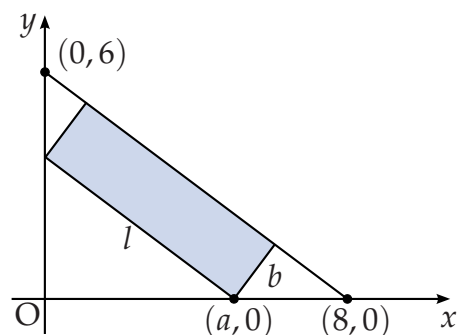

- (a) (i) Show that $l = \frac{5}{4}a$.
- (ii) Express b in terms of a and hence deduce that the area, $A \text{ m}^2$, of the extension is given by $A = \frac{3}{4}a(8 - a)$. 3
- (b) Find the value of a which produces the largest area of the extension. 4

4. The parabolas with equations $y = 10 - x^2$ and $y = \frac{2}{5}(10 - x^2)$ are shown in the diagram below.

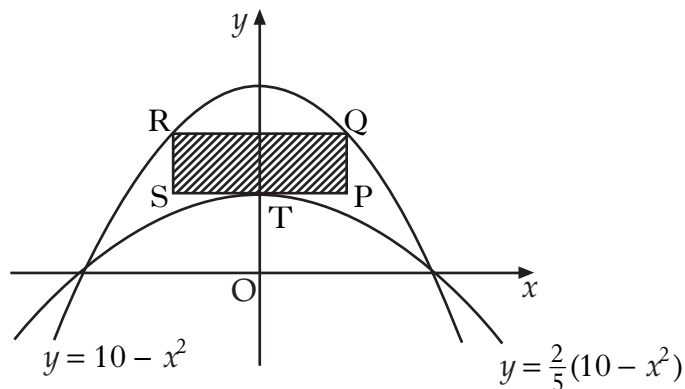

A rectangle PQRS is placed between the two parabolas as shown, so that:

- Q and R lie on the upper parabola.
 - RQ and SP are parallel to the x-axis.
 - T, the turning point of the lower parabola, lies on SP.
- (a) (i) If $TP = x$ units, find an expression for the length of PQ.
(ii) Hence show that the area, A , of rectangle PQRS is given by

$$A(x) = 12x - 2x^3. \quad 3$$

- (b) Find the maximum area of this rectangle. 6

[SQA]

5. Diagram 1 is an artist's impression of a new warehouse based on the architect's plans. The warehouse is in the shape of a cuboid and is supported by three identical parabolic girders spaced 30 metres apart.

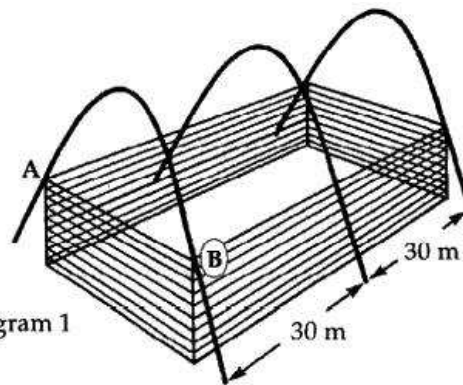

Diagram 1

With coordinate axes as shown in Diagram 2, the shape of each girder can be described by the equation $y = 9 - \frac{1}{4}x^2$.

- (a) Given that AB is $2x$ metres long, show that the shaded area in Diagram 2 is $(18x - \frac{1}{2}x^2)$ square metres.

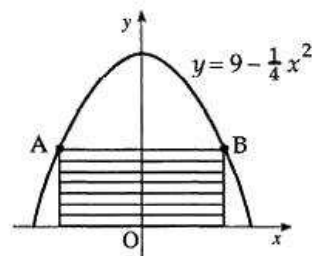

Diagram 2

(2)

- (b) The architect wished to fit into the girders the cuboidal warehouse which had the maximum volume. Find the value of this maximum volume.

(6)

[SQA]

6. The owners of a zoo intend to build a new aviary in the shape of a cuboid with a square floor. The volume of the aviary will be 500 m^3 .

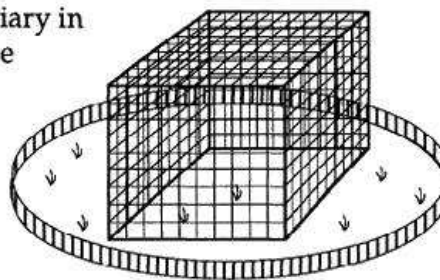

- (a) If x metres is the length of one edge of the floor, show that the area A square metres of netting required is given by

$$A = x^2 + \frac{2000}{x}.$$

(4)

- (b) Find the dimensions of the aviary to ensure that the cost of netting is minimised.

(6)

[SQA]

7. An yacht club is designing its new flag. The flag is to consist of a red triangle on a yellow rectangular background. In the yellow rectangle $ABCD$, AB measures 8 units and AD is 6 units. E and F lie on BC and CD , x units from B and C as shown in the diagram.

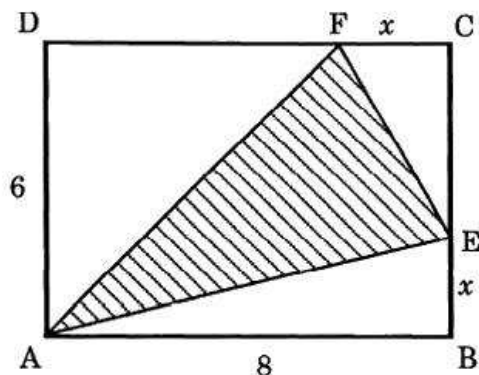

- (a) Show that the area, H square units, of the red triangle AEF is

$$\text{given by } H(x) = 24 - 4x + \frac{1}{2}x^2.$$

(4)

- (b) Hence find the greatest and least possible values of the area of triangle AEF .

(8)

[SQA]

8. A window in the shape of a rectangle surmounted by a semicircle is being designed to let in the maximum amount of light.

The glass to be used for the semicircular part is stained glass which lets in one unit of light per square metre; the rectangular part uses clear glass which lets in 2 units of light per square metre.

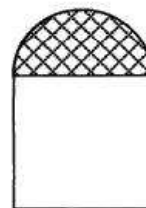

The rectangle measures $2x$ metres by h metres.

- (a) (i) If the perimeter of the whole window is 10 metres, express h in terms of x .

(2)

- (ii) Hence show that the amount of light, L , let in by the window is given by $L = 20x - 4x^2 - \frac{3}{2}\pi x^2$.

(2)

- (b) Find the values of x and h that must be used to allow this design to let in the maximum amount of light.

(5)

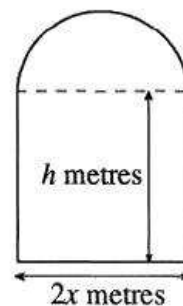

[SQA]

9. A cuboid is to be cut out of a right square-based pyramid. The pyramid has a square base of side 8 cm, and a vertical height of 10cm.

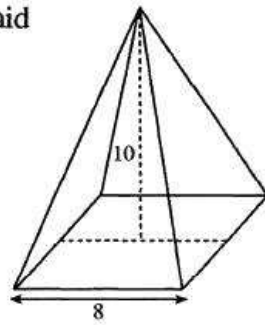

- (a) The cuboid has a square base of side $2x$ cm and a height of h cm.

If the cuboid is to fit into the pyramid, use the information shown in triangle ABC, or otherwise, to show that

- (i) $h = 10 - \frac{5}{2}x$.
(ii) the volume, V , of the cuboid is given by $V = 40x^2 - 10x^3$.

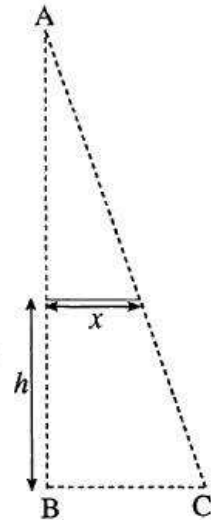
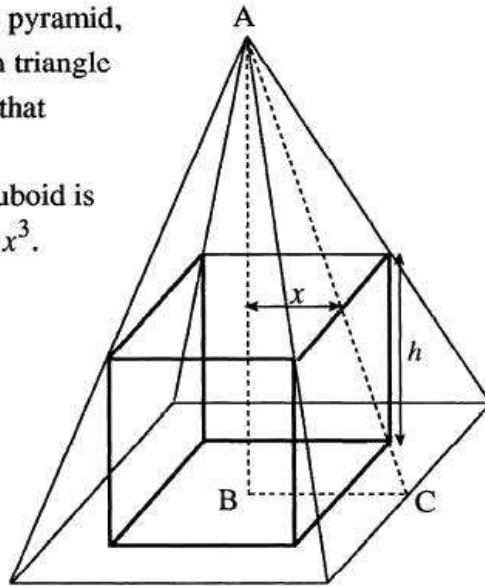

(3)

(1)

- (b) Hence find the dimensions of the square-based cuboid with the greatest volume which can be cut from the pyramid.

(6)

- [SQA] 10. A child's drinking beaker is in the shape of a cylinder with a hemispherical lid and a circular flat base. The radius of the cylinder is r cm and the height is h cm. The volume of the cylinder is 400 cm^3 .

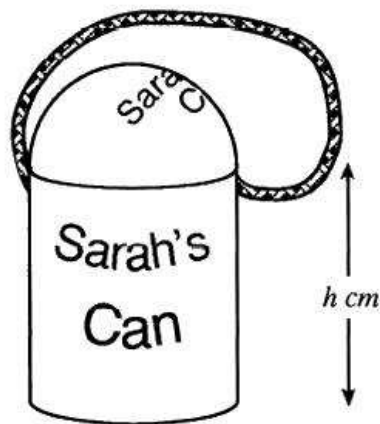

- (a) Show that the surface area of plastic, $A(r)$, needed to make the beaker is given by $A(r) = 3\pi r^2 + \frac{800}{r}$. (3)

Note: The curved surface area of a hemisphere of radius r is $2\pi r^2$.

- (b) Find the value of r which ensures that the surface area of plastic is minimised. (6)

- [SQA] 11. A zookeeper wants to fence off six individual animal pens.

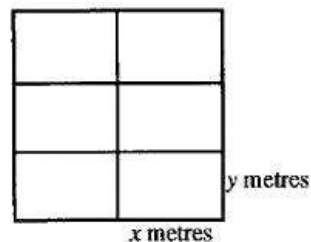

Each pen is a rectangle measuring x metres by y metres, as shown in the diagram.

- (a) (i) Express the total length of fencing in terms of x and y .
 (ii) Given that the total length of fencing is 360m, show that the total area, $A \text{ m}^2$, of the six pens is given by $A(x) = 240x - \frac{16}{3}x^2$. (4)
- (b) Find the values of x and y which give the maximum area and write down this maximum area. (6)

- [SQA] 12. Linktown Church is considering designs for a logo for their Parish magazine. The 'C' is part of a circle and the centre of the circle is the mid-point of the vertical arm of the 'L'. Since the 'L' is clearly smaller than the 'C', the designer wishes to ensure that the total length of the arms of the 'L' is as long as possible.

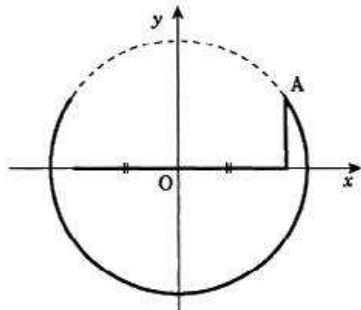
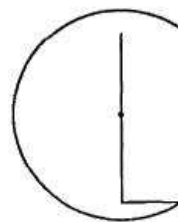

The designer decides to call the point where the 'L' and 'C' meet A and chooses to draw co-ordinate axes so that A is in the first quadrant. With axes as shown, the equation of the circle is $x^2 + y^2 = 20$.

- (a) If A has co-ordinates (x,y) , show that the total length T of the arms of

the 'L' is given by $T = 2x + \sqrt{20 - x^2}$. (1)

- (b) Show that for a stationary value of T , x satisfies the equation

$$x = 2\sqrt{20 - x^2}. \quad (5)$$

- (c) By squaring both sides, solve this equation.

Hence find the greatest length of the arms of the 'L'. (3)

- [SQA] 13. An oil production platform, $9\sqrt{3}$ km offshore, is to be connected by a pipeline to a refinery on shore, 100 km down the coast from the platform as shown in the diagram.

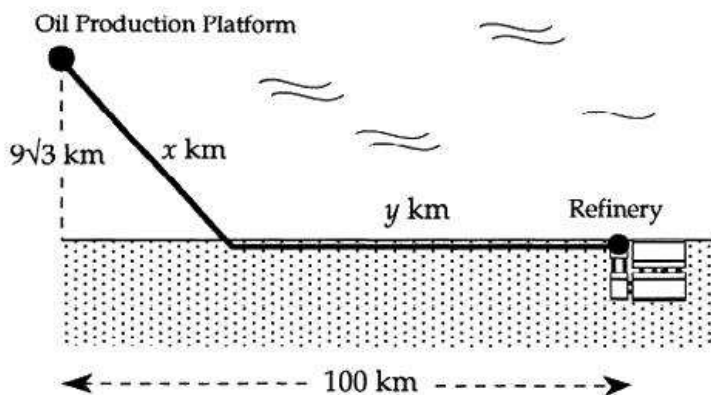

The length of underwater pipeline is x km and the length of pipeline on land is y km. It costs £2 million to lay each kilometre of pipeline underwater and £1 million to lay each kilometre of pipeline on land.

- (a) Show that the total cost of this pipeline is £ $C(x)$ million where

$$C(x) = 2x + 100 - \left(x^2 - 243\right)^{\frac{1}{2}}. \quad (3)$$

- (b) Show that $x = 18$ gives a minimum cost for this pipeline.
Find this minimum cost and the corresponding total length of the pipeline. (7)

[END OF QUESTIONS]