



National  
Qualifications  
2022 MODIFIED

**X802/77/11**

**Mathematics  
of Mechanics**

WEDNESDAY, 11 MAY

1:00 PM – 3:50 PM

**Total marks — 90**

Attempt ALL questions.

**You may use a calculator.**

To earn full marks you must show your working in your answers.

State the units for your answer where appropriate. Any rounded answer should be accurate to an appropriate number of significant figures unless otherwise stated.

Write your answers clearly in the spaces provided in the answer booklet. The size of the space provided for an answer is not an indication of how much to write. You do not need to use all the space.

Additional space for answers is provided at the end of the answer booklet. If you used this space you must clearly identify the question number you are attempting.

Use **blue** or **black** ink.

Before leaving the examination room you must give your answer booklet to the Invigilator; if you do not you may lose all the marks for this paper.



\* X 8 0 2 7 7 1 1 \*

## FORMULAE LIST

### Newton's inverse square law of gravitation

$$F = \frac{GMm}{r^2}$$

### Simple harmonic motion

$$v^2 = \omega^2(a^2 - x^2)$$

$$x = a \sin(\omega t + \alpha)$$

### Centre of mass

Triangle:  $\frac{2}{3}$  along median from vertex.

Semicircle:  $\frac{4r}{3\pi}$  along the axis of symmetry from the diameter.

Coordinates of the centre of mass of a uniform lamina, area  $A$  square units, bounded by the equation  $y = f(x)$ , the  $x$ -axis and the lines  $x = a$  and  $x = b$  is given by

$$\bar{x} = \frac{1}{A} \int_a^b xy \, dx \quad \bar{y} = \frac{1}{A} \int_a^b \frac{1}{2} y^2 \, dx$$

Standard derivatives	
$f(x)$	$f'(x)$
$\tan x$	$\sec^2 x$
$\cot x$	$-\operatorname{cosec}^2 x$
$\sec x$	$\sec x \tan x$
$\operatorname{cosec} x$	$-\operatorname{cosec} x \cot x$
$\ln x$	$\frac{1}{x}$
$e^x$	$e^x$

Standard integrals	
$f(x)$	$\int f(x) dx$
$\sec^2(ax)$	$\frac{1}{a} \tan(ax) + c$
$\frac{1}{x}$	$\ln x  + c$
$e^{ax}$	$\frac{1}{a} e^{ax} + c$

Note that  $g \text{ m s}^{-2}$  denotes the magnitude of the acceleration due to gravity. Where appropriate, take its magnitude to be  $9.8 \text{ m s}^{-2}$ .

1. An object of mass 8 kg is at rest on a smooth horizontal surface. A constant horizontal force of magnitude 65 newtons is applied for 1.2 seconds.

(a) Calculate the speed of the object after this time. 2

The object then hits a wall and rebounds in the opposite direction with no loss of energy.

(b) Calculate the magnitude of the impulse of the wall on the object. 2

2. Express the function  $f(x) = \frac{2 - 3x - x^2}{(1+x)(1-x)^2}$  as a sum of partial fractions. 3

3. A ball is kicked from horizontal ground with a speed of  $25 \text{ m s}^{-1}$  at an angle of  $30^\circ$  to the horizontal.

(a) Calculate the maximum height of the ball. 2

As the ball falls it is caught at a height of 1 metre from the ground.

(b) Calculate the total horizontal displacement of the ball during its motion. 3

4. A particle moves with simple harmonic motion about a point O.

The particle starts from its extreme position and first reaches a maximum speed of  $6 \text{ m s}^{-1}$  after 4 seconds.

(a) State the period of the motion. 1

(b) Hence, or otherwise, calculate the amplitude of the motion. 2

5. An object is launched along the  $x$ -axis, from the origin, with an initial velocity of  $5 \text{ m s}^{-1}$ .

The subsequent motion can be modelled by the equation

$$\frac{d^2x}{dt^2} + \frac{dx}{dt} - 6x = 0.$$

Find the particular solution for  $x$  in terms of  $t$  where  $x$  is measured in metres and  $t$  is measured in seconds. 5

6. A body moves with an initial velocity  $u \text{ m s}^{-1}$  in a straight line on a smooth horizontal surface.

It travels with a constant acceleration of  $a \text{ m s}^{-2}$ .

After  $t$  seconds it has a velocity  $v \text{ m s}^{-1}$ .

(a) Use calculus to show that  $v = u + at$ .

2

(b) Hence, derive an expression for its displacement,  $s$  metres, from its original position in terms of  $u$ ,  $a$  and  $t$ .

2

7. Use integration by parts to find  $\int 18x \sin 3x \, dx$ .

3

8. A small object of mass  $m$  kilograms is placed on a rough horizontal disc, at a distance of 0.07 metres from the centre. When the disc is rotated at a rate of 1.5 revolutions per second, the object is on the point of slipping.

Calculate the coefficient of friction between the disc and the object.

5

9. An object is formed by rotating the curve  $y = \frac{6x}{3x^3 - 1}$  between  $x = 1$  and  $x = 2$ , through  $2\pi$  radians about the  $x$ -axis.

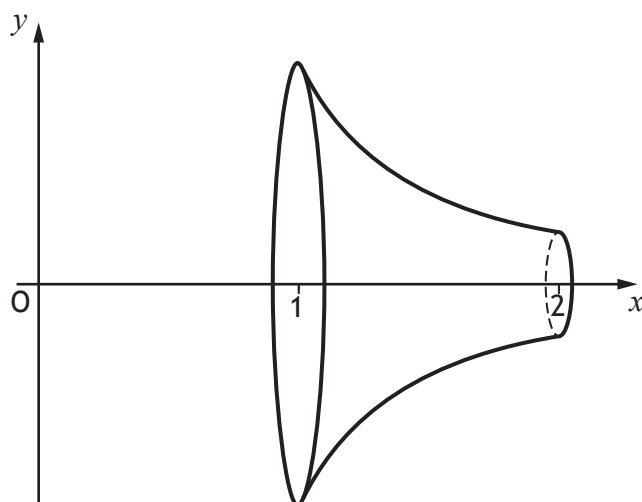

Using the substitution  $u = 3x^3 - 1$ , or otherwise, find the exact value of the volume of this object.

6

10. A particle of mass 0.1 kg is suspended from a fixed point O by a light inextensible rod of length 30 cm.

The rod is rotating in a vertical circle with diameter AB and makes an angle  $\theta$  with OB.

The particle has a speed of  $1.2 \text{ m s}^{-1}$  at A.

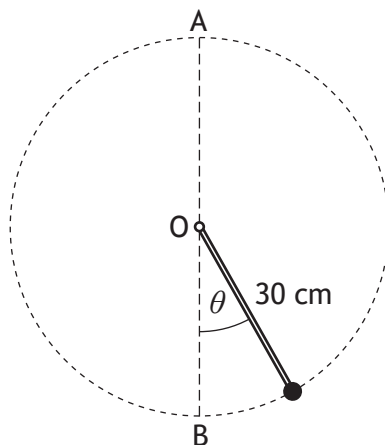

- (a) Use conservation of energy to find the speed of the particle at B. 2
- (b) Find the tension in the rod when the particle is at A and interpret your answer. 3
- (c) Find the size of the angle  $\theta$  when the tension in the rod is zero. 5
11. Find the particular solution of the differential equation

$$\frac{dy}{dx} - \frac{y}{x} = x e^{2x}$$

given that  $y = \frac{3}{2} e^2$  when  $x = 1$ .

Express your answer in the form  $y = f(x)$ .

6

[Turn over

12. A box of mass  $m$  kg is at rest on a rough slope inclined at an angle  $\theta^\circ$  to the horizontal. It is held in place by an external force of magnitude  $F$  newtons, which is at the same angle  $\theta^\circ$  to the slope, as shown in the diagram.

MARKS

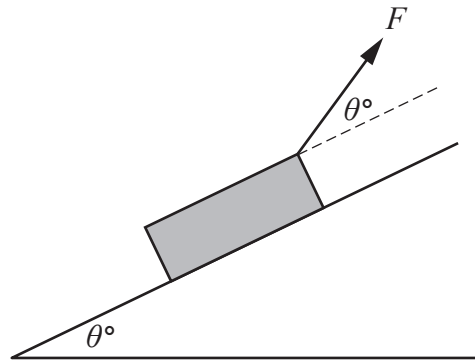

- (a) The box is on the point of sliding down the slope when  $F$  is equal to  $\frac{1}{2}mg$ .

Show that  $\mu = \frac{2 \tan \theta^\circ - 1}{2 - \tan \theta^\circ}$ .

5

When  $\theta^\circ = 30^\circ$ , the external force is increased so that the box is on the point of moving up the slope.

- (b) Determine the magnitude of the new force. Express your answer in the form  $kmg$ , where  $k$  is a constant.

5

13. A function is defined as  $f(x) = \frac{\sec x}{\tan x + 1}$ , where  $0 \leq x < \frac{\pi}{2}$ .

- (a) Show that  $f'(x) = f(x) \left( \frac{\tan x - 1}{\tan x + 1} \right)$ , given that  $1 + \tan^2 x = \sec^2 x$ .

3

- (b) Hence find  $\int \frac{\tan x - 1}{\tan x + 1} dx$ .

2

14. A particle of mass 5 kg is initially at rest. It is projected horizontally from an origin, O, along the positive direction of the  $x$ -axis.

The particle moves with variable acceleration given by  $a = (15 + x - 2x^2) \text{ms}^{-2}$ ,  $x \geq 0$  where  $x$  is measured in metres.

- (a) Calculate the displacement from O at which the particle reaches its maximum speed.

2

- (b) (i) Calculate the work done in reaching this maximum speed.

3

- (ii) Hence, or otherwise, calculate the maximum speed.

2

15. A jet takes off from an origin with an initial velocity of  $\begin{pmatrix} 240 \\ 0 \\ 50 \end{pmatrix} \text{ kmh}^{-1}$ .
- It then accelerates in a straight line at a constant rate of  $\begin{pmatrix} 3000 \\ 0 \\ 80 \end{pmatrix} \text{ kmh}^{-2}$  for 12 minutes.

- (a) (i) Calculate the speed of the jet at this time. 2
- (ii) Find the position of the jet at this time. 2

The jet now maintains this speed but on a horizontal course parallel to the  $x$ -axis.

A wind blows with velocity  $\begin{pmatrix} -10 \\ -50 \\ 0 \end{pmatrix} \text{ kmh}^{-1}$ .

- (b) (i) Calculate the angle at which the jet is blown off course. 2
- (ii) Calculate the horizontal component of the displacement of the jet, 90 minutes after take-off. 3

16. A particle of mass 0.1 kg is launched at an acute angle to the horizontal, from the origin, with a kinetic energy of 20 joules. It moves in a vertical  $x$ - $y$  plane under the influence of gravity and there is no resistance to motion.

- (a) Find the speed of the particle when it is at a height of 10 metres. 2
- (b) Find the height of the particle when it has a velocity of  $\begin{pmatrix} 4 \\ 5 \end{pmatrix} \text{ m s}^{-1}$ . 2
- (c) Determine the kinetic energy of the particle at its maximum height. 1

[END OF QUESTION PAPER]